



Flüssiggas-Anlagen

»Group 25«

Accessories for Loading / Offloading

Equipment

Torch

Loading Arm Stations

Swivel Joints



Flüssiggas-Anlagen GmbH • Peiner Straße 217 • D - 38229 Salzgitter (Germany)
Tel. +49 (0) 53 41 / 86 97-0 • Fax +49 (0) 53 41 / 86 97-11
E-Mail: info@fas-uni.de • <http://www.fas-uni.de>



Liquid and Vapour Transfer Hose System in Full Hose System PN 25, standard connections for road tankers, respectively rail tankers, complete with valves and connections, hose systems are tested at a hydrostatic pressure of 37,5 bar for leakage and to insure that all fittings are securely installed, with test certificate to TRG 402

Type: **A** = with a length of **4 metres**
Type: **B** = with a length of **5 metres**

Filler Hose for Road Tankers with safety relief valve 25 bar and venting device

Order no.	Order no.	Execution
Type A	Type B	
25 021	25 221	High-pressure hose LPG 80, connections: one side ball valve DN 65 PN 40 with coupling 3 1/4" ACME with union nut and plug of brass, other side flange DN 80 PN 40 to DIN 2635
25 022	25 222	High-pressure hose LPG 50, connections: one side ball valve DN 50 PN 40 with coupling 3 1/4" ACME with union nut and plug of brass, other side flange DN 50 PN 40 to DIN 2635

Vapour Transfer Hose for Road Tankers without safety relief valve 25 bar and venting device

Order no.	Order no.	Execution
Type A	Type B	
25 023	25 223	High-pressure hose LPG 50, connections: one side ball valve DN 50 PN 40 with coupling 2 1/4" ACME with union nut and plug of brass, other side flange DN 50 PN 40 to DIN 2635
25 024	25 224	High-pressure hose LPG 32, connections: one side ball valve DN 32 PN 40 with coupling 2 1/4" ACME with union nut and plug of brass, other side flange DN 32 PN 40 to DIN 2635

Filler hose for Rail Tankers with safety relief valve 25 bar and venting device

Order no.	Order no.	Execution
Type A	Type B	
25 031	25 231	High-pressure hose LPG 80, connections: one side ball valve DN 65 PN 40 with lapped DIN flange DN 80 PN 40 and installed blind flange, other side flange DN 80 PN 40 to DIN 2635

Vapour Transfer Hose for Rail Tankers without safety relief valve 25 bar and venting device

Order no.	Order no.	Execution
Type A	Type B	
25 032	25 232	High-pressure hose LPG 50, connections: one side ball valve DN 50 PN 40 with lapped DIN flange DN 50 PN 40 and installed blind flange, other side flange DN 50 PN 40 to DIN 2635

Further executions, other lengths or connections with ANSI flange are available on request.

Mechanical Rail Hook for rail tankers for automatic maintaining of the internal valve at the rail tanker in open position, outer parts of bronze/brass (sparkproof), holding load 350 N, fire protection 150 °C, with test report 2.2 to EN 10 204

The ratchet, which anchors the rail hook on the rail, is prestressed by means of resilience. When displacing the rail tanker, the ratchet latches by 90°, releases from the rail and the internal valves close automatically. A release by pull cord mechanism is also possible by remote control.

Order no.	Execution	Weight
25 045	Mechanical rail hook	5,8



Pneumatic Rail Hook with Actuator operated by taut cable, for fixed installation in front of rail tanker, with base plate holding devices and weather-proof cover, with traction rope and chain, with a limit switch¹⁾ (inductive sensor) for position "EMERGENCY-OFF". In connection with a 3/2-way solenoid valve this device may be integrated in the **EMERGENCY-OFF System**.

Order no.	Execution	Weight
25 048	Pneumatic actuator unit	30,0
Order no.	Accessories	Weight
19 713	3/2-way solenoid valve, explosion-proof, for product compressed-air max.10 bar, thread connection G 1/4", 230 V, 50 Hz	1,4
19 714	3/2-way solenoid valve, explosion-proof, for product compressed-air max.10 bar, thread connection G 1/4", 24 V direct current	1,4
26 305	Isolating switch amplifier in safety construction, control current circuit intrinsically safe, 1 change-over contact, 230 V, 50 Hz, TÜV- tested	0,3
25 043	Limit switch ²⁾ (inductive sensor) for position "operation"	0,1
26 301	Isolating switch amplifier, control current circuit intrinsically safe, 1 change-over contact, 230 V, 50 Hz	0,3

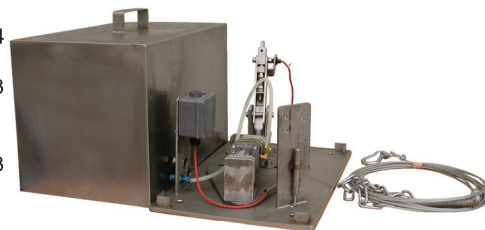

¹⁾ Explosion-proof with isolating switch amplifier, order no. 26 305 (230V)
²⁾ Explosion-proof with isolating switch amplifier, order no. 26 301 (230V)

Suspension Device swinging arm, type FAS, for LPG filler hose and vapour transfer hose system for easy handling and screwing tight of the hose connection to the rail tanker, with test report 2.2 to EN 10 204 (DIN 50.049-2.2)

Order no.	arm length	max. load
25 052	1700 - 2100 mm	73 kg

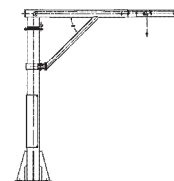

When placing your order please indicate the weight of the hose at the point of suspension.

Loading Arm Station PN 25, type FAS-G5, with two product arms (liquid and vapour phase), for the loading and offloading of road tankers or rail tankers, completely mounted and primed

consisting of:

- Loading arm DN 80 (liquid phase)
connection road tanker: coupling 3/4" ACME with union nut and filler plug, respectively
connection rail tanker: lapped flange DN 80 with installed blind flange
- Loading arm DN 50 (vapour phase)
connection road tanker: coupling 2/4" ACME with union nut and filler plug, respectively
connection rail tanker: lapped flange DN 50 with installed blind flange
- Flanged ball valve DN 50 and DN 80, FIRE-SAFE to BS 6755 Part 2
- ERC-safety breakaway coupling DN 50 and DN 80 (emergency breakaway protection) with release system, mechanical execution
- Ball valve 1/2" NPT for tension release
- Vent hose line LPG 10 for propane/ butane, respectively flexible stainless steel hose line for ammonia NH₃
- Support column with thrust bearing system and 2 parking position locks
- Hydraulic / pneumatic balance system for easy operation and handling

Tests / Approvals:

- Fittings with inspection certificate 3.1.B to EN 10 204, respectively test report 2.2 to EN 10 204
- TÜV-certificate for the construction, pressure and tightness test
- 10 % X-ray of welding seams

Type: **A** = for propane/butane

Type: **B** = for ammonia NH₃

Order no.

Type A	Execution
25 302	Road tanker
25 304	Rail tanker

Order no.

Type B	Execution
25 307	Road tanker
25 309	Rail tanker

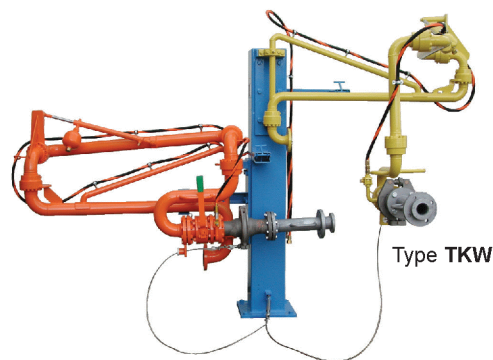

Additional Service:

Order no.	Service
25 390	Delivery and installation of the Loading Arm Station on the foundation finished by customer
25 394	Commissioning
25 392	Painting of the complete Loading Arm Station
25 399	X-ray 100 % of welding seams

Subject to technical modifications.

Loading Arm Stations with other dimensions and ANSI-connections for other media on request.

Bottom Loading Arms Station with three product arms are available with FAS-No. 25 403 and 25 404 for LPG and FAS-No. 25 461 and 25 462 for ammonia.

Accessories and additional equipment for Loading Arm Stations

Order no.	Execution
25 298	Proximity switch for signalling of parking position or for the release of the safety breakaway coupling, Explosion-proof with isolating limit switch order no. 26 305 (230V)
26 305	Isolating limit switch in safety design, control current circuit intrinsically safe, 1 change-over contact, 230 V, 50 Hz, with TÜV-certificate
25 291	Installation of one proximity switch for control of the parking position on the loading arm station type FAS-G7, completely cabled and with connection box on the stand post
25 299	Installation of two proximity switches for control of the parking position on the loading arm station type FAS-G5 and type FAS-G4, completely cabled and with connection box on the stand post
25 292	Installation of three proximity switches for control of the parking position on the loading arm station type FAS-G6, completely cabled and with connection box on the stand post
25 293	Installation of one proximity switch for the signal release of the safety breakaway coupling on the loading arm station type FAS-G7, completely cabled and with connection box on the stand post
25 300	Installation of two proximity switches for the signal release of the safety breakaway coupling on the loading arm stations type FAS-G5 and type FAS-G4, completely cabled and with connection box on the stand post
25 294	Installation of three proximity switches for the signal release of the safety breakaway coupling on the loading arm station, type FAS-G6, completely cabled and with connection box on the stand post
25 343	Special sealing for screw plug on high-pressure tank
25 295	Automatic tightness testing device with special test flange and special sealing DN 80 PN 40 for liquid phases of rail tanker product arm
25 435	Filling and testing device for safe filling process or control of the pressure tank consisting of: <ul style="list-style-type: none"> - Plastic box with - Filler and check valve - Pressure gauge 0 - 250 bar - Hose length = 2,5 metres

Spare parts set with shear pin and O-ring for ERC safety breakaway coupling see page 18.

Top Loading Arm Station PN 25, type FAS, with two product arms, for the loading and offloading of LPG (propane/butane) road tankers and rail tankers with top connection, but without safety breakaway couplings (emergency breakaway protection), completely mounted and primed.
Our scope of supply does not include the complete loading gantry, steel work constructions and stand post. These components must be manufactured and installed at side.

Consisting of:

- Loading arm for liquid phase
- Loading arm for vapour phase
- Flanged ball valve, FIRE-SAFE acc. to BS 6755 Part 2
- Ball valve 1/2" NPT for venting
- Vent hose line LPG 10 for propane/ butane
- Connecting steel plate for stand post with thrust bearing system and 2 parking position locks
- Hydraulic / pneumatic balance system for easy operation and handling

Tests / Approvals:

- Fittings with inspection certificate 3.1.B to EN 10 204, respectively test report 2.2 to EN 10 204
- TÜV-certificate for the construction, pressure and tightness test
- 10 % X-ray of welding seams

Type: **A** = with DIN flange connection PN 25/40

Type: **B** = with ANSI flange connection 300 lbs R.F.

Order no.	Execution	
Type A	Liquid line	Vapour line
25 406	DN 50 / 2"	DN 50 / 2"
25 407	DN 80 / 3"	DN 50 / 2"

Order no.	Execution	
Type B	Liquid line	Vapour line
25 410	DN 50 / 2"	DN 50 / 2"
25 411	DN 80 / 3"	DN 50 / 2"

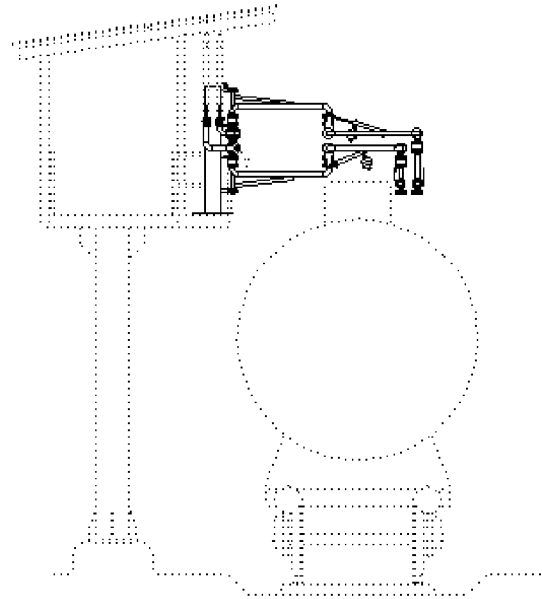

Extra charge for service, e.g. painting, X-ray etc. see below. Other executions are available on request.

Subject to technical modifications.

Loading Arm Station PN 25, type FAS-G7, with one product arm (liquid phase), for the loading and offloading of road tankers or rail tankers, completely mounted and primed

consisting of:

- Loading arm DN 80 or DN 50, for road tankers, connection ACME-coupling with union nut and filler plug, respectively for rail tanker: connection lapped flange DN 80 with installed blind flange
- Flanged ball valve DN 50 or DN 80, FIRE-SAFE according to BS 6755 Part 2
- ERC-safety breakaway coupling DN 50 or DN 80 (emergency breakaway protection) with release system, mechanical execution
- Ball valve 1/2" NPT for venting
- Vent hose line LPG 10 for propane/ butane, respectively flexible stainless steel hose line for ammonia NH₃
- Stand post with thrust bearing system and parking position lock
- Hydraulic / pneumatic balance system for easy operation and handling

Tests / Approvals:

- Fittings with inspection certificate 3.1.B to EN 10 204, respectively test report 2.2 to EN 10 204
- TÜV-certificate for the construction, pressure and tightness test
- 10 % X-ray of welding seams

Type: **A** = for propane/butane

Type: **B** = for ammonia NH₃

Loading Arm DN 80

Order no.	Order no.	Execution	Connection
Type A	Type B		
25 451	25 468	road tanker	3 1/4" ACME
25 452	25 469	rail tanker	DN 80

Loading Arm DN 50

Order no.	Order no.	Execution	Connection
Type A	Type B		
25 401	25 464	road tanker	2 1/4" ACME
25 402	25 465	rail tanker	DN 50

Additional Service:

Order no.	Service
25 390	Delivery and installation of the Loading Arm Station on the foundation finished by customer
25 394	Commissioning
25 391	Painting of the complete Loading Arm Station
25 398	X-ray 100 % of welding seams



Subject to technical modifications.

Loading Arm Stations with other dimensions, ANSI-connections and for other products on request.

Loading Arm Station PN 25, type FAS-G4, for propane/butane, with two product arms (liquid and vapour phase), for the loading and offloading of road tankers, completely mounted and primed

consisting of:

- Two loading arms DN 50, connection liquid phase with coupling 3 1/4" ACME with union nut and filler plug, connection vapour phase coupling 2 1/4" ACME with union nut and filler plug
- Flanged ball valve DN 50 PN 40, FIRE-SAFE according to BS 6755 Part 2
- ERC-safety breakaway coupling DN 50 (emergency breakaway protection) with release system, mechanical execution
- Ball valve 1/2" NPT with hose line LPG 10 for venting
- Stand post with thrust bearing system and 2 stowing position locks
- Balancing of arms by gas hydraulic cylinder for easy operation

Tests / Approvals:

- Fittings with inspection certificate 3.1.B to EN 10 204, respectively test report 2.2 to EN 10 204
- TÜV-certificate for the construction, pressure and tightness test
- 10 % X-ray of welding seams

Order no. Execution
25 466 road tanker

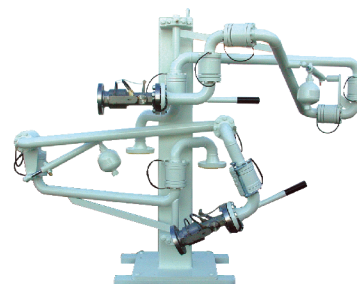

Additional equipment, option and further services see page 91.

Further executions, e.g. dry break couplings or with ANSI-flange connections are available on request.

Swivel Joint PN 40, for propane/butane, straight construction, three-piece body, steel, welding ends on both sides, seal of PTFE, with inspection certificate 3.1.B to EN 10 204

Due to this three-piece construction an exchange of the swivel joint head is possible without difficulties.

Order no.	Size	Overall length	Weight
25 076	DN 50 / 2"	170	8,8
25 078	DN 80 / 3"	175	12,0



Alternative constructions with pipe bends, flanges according to DIN or ANSI/ASA available on request.
Further sizes, other materials and special executions also for other products on request.

Swivel Joint PN 40, straight construction, two-piece body, welding ends on both sides, seal of PTFE, with inspection certificate 3.1.B to EN 10 204

Type: **A** = stainless steel for ammonia NH₃

Type: **B** = steel for propane/ butane

Order no.	Order no.	Connection Size	Overall length (mm)	Weight (kg)
25 064	25 084	DN 32 / 1 1/4"	90	3,5
25 066	25 086	DN 50 / 2"	145	7,2
25 068	25 088	DN 80 / 3"	155	11,8



Alternative constructions with pipe bends, flanges according to DIN or ANSI/ASA available on request.
Further sizes, other material and special executions also for other products on request.

Swivel Joint PN 25, for propane/butane, for hose and pipe connections, seal of PTFE, with test report 2.2 to EN 10 204

Type: **A** = angular construction 90°, steel, both sides female NPT

Type: **B** = straight construction, steel, both sides female NPT

Type: **C** = straight construction, steel, one side female NPT, other side male NPT

Order no.	Order no.	Order no.	Connection	Weight	Weight	Weight
Type A	Type B	Type C	NPT	Type A	Type B	Type C
25 161	25 171	25 182	3/4"	3,2	2,2	0,9
25 162	25 172	25 183	1"	3,2	2,2	0,9
25 163	25 173	25 186	1 1/4"	3,0	2,0	1,2
25 164	25 174	-	1 1/2"	5,9	5,4	-
25 165	25 175	-	2"	5,6	5,0	-



Type A



Type B

Further types of construction, as well as repair sets on request.

Torch for safe burning of vapour and liquid propane/butane from underground and aboveground tanks, complete with all necessary safety fittings and valves, with test report 2.2 to EN 10 204

Stable and galvanized steel construction including burner with vaporizer tube coil, 3 removable supports, with brackets for fixing on foundation plate, with automatic ignition device and flashback arrestor, ignition transformer with protection housing and 20 metres cable with plug, inlet with solenoid valve 230 V 50 Hz, sun protection shed for valves and fittings, connection 1 3/4" ACME male, total height approx. 3.500 mm, space required for erection approx. 9 m²

Order no. **25 290**

