



Flüssiggas-Anlagen

»Group 20«

Vaporizers and Vaporizer Systems



Flüssiggas-Anlagen GmbH • Peiner Straße 217 • D - 38229 Salzgitter (Germany)
Tel. +49 (0) 53 41 / 86 97-0 • Fax +49 (0) 53 41 / 86 97-11
E-Mail: info@fas-uni.de • <http://www.fas-uni.de>



Wet-Type Vaporizer PN 25, type FAS 3000, for propane / butane, with insulation, explosion-proof, zone 1, indirectly heated by hot water, vertical tube bundle version, design, manufacture and testing in accordance with AD requirements and regulations for pressure vessels, approved by TÜV, with redundant anti-flood protection, complies with safety requirements for LPG installations (TRB 801/25)

Vaporizer unit includes:

- Twin thermostat for monitoring gas temperature
- Level sensor for double anti-flood protection
- Double solenoid valve in liquid inlet (Type A) or Single solenoid valve in liquid inlet (Type B)
- Safety relief valve in vapour phase
- Thermostat for gas temperature
- Thermostat in water inlet and outlet
- Pressure switch in water room
- Ball valves for draining and venting
- Separate electrical control cubicle for installation outside of hazardous areas

Electrical Components:

in accordance with VDE, protection class IP 54, power supply 230 V / 50 Hz

Connecting cables between vaporizer and electrical control cubicle are not included.

Design Data:

Calculated Pressure: LPG 25 bar, water 10 bar
 Calculated Temperature: LPG 100°C, water 100°C
 Temperature of Heat Transfer Medium: 90° / 70°C



Order No. Type A	Order No. Type B	Capacity kg/h	LPG (DIN-flange PN 40)		Water (DIN-flange PN 16)		Length L mm	Weight kg
			Inlet S1 DN	Outlet S2 DN	Inlet S3 DN	Outlet S4 DN		
20 151	20 141	200	20	40	25	25	1975	120
20 152	20 142	300	25	50	32	32	2475	135
20 153	20 143	400	32	65	40	40	2000	200
20 154	20 144	600	32	65	50	50	2500	225
20 155	20 145	800	40	65	50	50	2100	305
20 156	20 146	1200	50	80	50	50	2600	380
20 157	20 147	1900	50	80	50	50	2625	400
20 158	20 148	2500	50	80	50	50	3125	450
20 159	20 149	3000	65	100	65	65	3220	640

Vaporizer Components

Pos.	Description
1	Vaporizer housing
2	vent / drain (LPG)
3	Thermostat (LPG)
4	Solenoid Valve (LPG)
5	vent / drain (Water)
6	Thermostat (Water)
7	Liquid Level Sensor (LPG)
8	Double Thermostat (LPG)
9	Relief Valve (LPG)
10	Pressure Switch (Water)

Schematic diagram

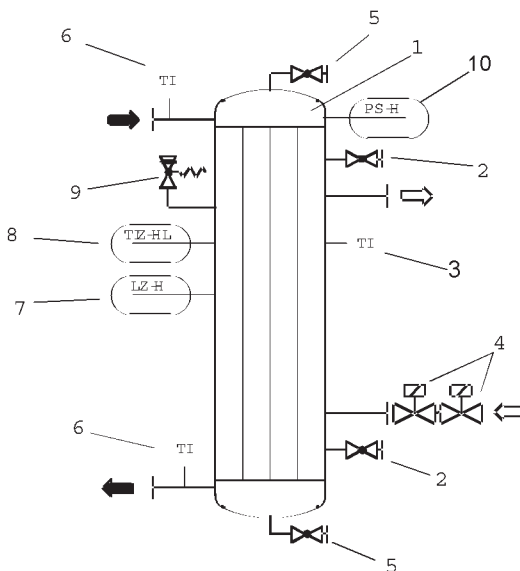

Special executions and higher capacities are available on request.

Dry-Type Vaporizer PN 25, type FAS 2000, suitable for use in hazardous area, Zone 2, for propane / butane, indirectly electrically heated, power supply threephase current 400 V/50 Hz, construction to DIN 30696, TRB 801/25 and VDE 0165, completely wired, cylindrical construction

The FAS-dry type vaporizer are completely maintenance-free and require no heat transfer fluid. An aluminium core is used as the heat transfer medium, in which the heating equipment and vaporizer system are cast. Using a thermostat, the heat transfer medium is heated and monitored within the limits specified by DIN standards. Once the required vaporizer temperature has been reached, the solenoid valves open. Liquid gas enters the vaporizer where it is converted to vapour without any fluctuations in pressure until the specified rated capacity has been reached. The modern design means that fluctuations in vapour flow are detected immediately and the required heating capacity is adjusted quickly to suit the new operation parameters. In case of power failure or overload, the solenoid valves close. An additional safety limit switch monitors the outlet temperature of the vapour and prevents it from exceeding a given limit.

The design and construction of the vaporizer guarantee safe and fully automatic operation even in hazardous areas, Zone 2.

Protective roof or steel cabinet necessary for outdoor installation.

Vaporizer unit includes:

Vaporizer housing in sheet steel construction with internal aluminium core, insulation, with cover and bracketry for mounting wall

Heating equipment in the form of a tubular heating element cast together with **vaporizer system**, pressure-bearing component made of seamless precision piping

Relief valve for vapour phase, setting pressure 25 bar, without weep-hole, type approval with TÜV-certificate

Heat and temperature control system fully automatically, thermostatically controlled within limits specified by DIN 30696

Anti-Flood / Low pressure protection - redundant - consisting of one or two thermostatically actuated solenoid valves in LPG inlet

Overheating protection with safety power switch off

Electrical Components in accordance to VDE 0165 (DIN 57 165) for Ex-Zone 2

Subject to technical changes.

Type: **A** = 2 solenoid valves in vaporizer inlet, vaporizer with TÜV-certificate (third party inspection)

Type: **B** = 1 solenoid valve in vaporizer inlet, vaporizer with manufacturer's certificate

Order No. Type A	Order No. Type B	Capacity kg/h	Connection Cutting Ring Union		Power Supply kW	Weight kg
			Inlet	Outlet		
20 403	20 423	32	15 mm	15 mm	6	34
20 404	20 424	60	15 mm	22 mm	12	76
20 405	20 425	100	15 mm	22 mm	18	105

We supply replacement parts and repair faulty vaporizers.



Type A (60 and 100 kg/h)

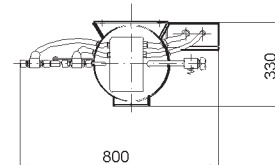
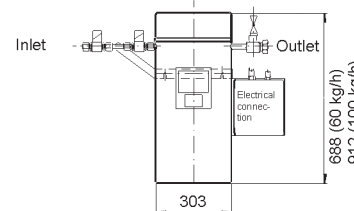

Type A (32 kg/h)

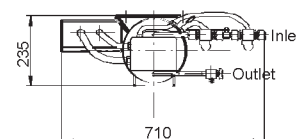
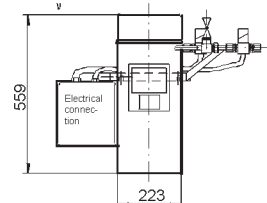

Dry-Type Vaporizer PN 25, type FAS 2000, suitable for use in hazardous area, Zone 2, for propane / butane, indirectly electrically heated, power supply single phase 230 V/50 Hz, construction to DIN 30696, TRB 801/25 and VDE 0165, completely wired, cylindrical construction

Construction, function, as well as scope of supply as above mentioned.

Type: **A** = 2 solenoid valves in vaporizer inlet, vaporizer with TÜV-certificate (third party inspection)

Type: **B** = 1 solenoid valve in vaporizer inlet, vaporizer with manufacturer's certificate

Order No. Type A	Order No. Type B	Capacity kg/h	Connection Cutting Ring Union		Power Supply kW	Weight kg
			Inlet	Outlet		
20 421	20 422	15	15 mm	15 mm	3	34

Type A (15 kg/h)

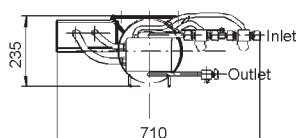
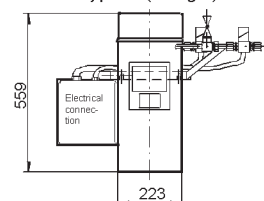

Vaporizer Unit in Cabinet Construction PN 25, with dry-type vaporizer, type FAS 2000, explosion-proof, Zone 2, for propane / butane, indirectly electrically heated, power supply 400 V/50 Hz, 3-phase, completely mounted in sheet steel cabinet with piping, dry-type vaporizer with TÜV-certificate

Vaporizer unit includes:

- Sheet steel cabinet, painted, with rain roof, with vent holes, base h=100 mm
- Ball valve in inlet and outlet and between liquid trap and middle pressure regulator
- Strainer with fine-mesh filter and safety relief valve in front of the dry-type vaporizer
- Dry-type vaporizer, type FAS 2000 (see order nos. **20 403 - 20 405**), for Ex-Zone 2, with 2 solenoid valves in vaporizer inlet, 1 safety relief valve in vaporizer outlet, control box at vaporizer, completely wired ready for connection
- Liquid trap with fine-mesh screen, gas deflector and drain valve
- Pressure gauge 0 - 25 bar with shut-off valve in front and behind the middle pressure regulator
- Middle pressure regulator PN 25 with emergency shut-off / relief valve, with DIN-DVGW-approval

Type: **A** = Outlet pressure 0,8 bar (32 kg/h and 60 kg/h) respectively 1,5 bar (100 kg/h)
 Type: **B** = Additionally with a low pressure regulator with emergency shut-off / relief valve, outlet pressure 50 mbar

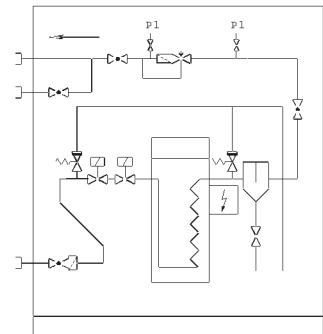

Type A + Order-Nr. 20 716
subject to technical alterations

Order No. Type A	Order No. Type B	Capacity kg/h	Dimensions H x W x D (mm) (Height x Width x Depth)	Pipe Connection Cutting Ring Union		Pressure Regulator Inlet Pressure	Weight kg
				Inlet	Outlet		
20 703	20 707	32	1200 x 800 x 400	15 mm, right	18 mm, right	1,5 - 16 bar	140
20 704	20 708	60	1600 x 1200 x 500	15 mm, left	22 mm, left	1,5 - 16 bar	270
20 705	20 709	100	1600 x 1200 x 500	15 mm, left	22 mm, left	2,5 - 16 bar	300

Inspection

- Order No. Execution
20 710 TÜV-certificate for construction, pressure and tightness test for the complete vaporizer system (third party inspection) to DIN-DVGW standards

Additional Equipment

- Order No. Execution
26 135 Liquid level sensor FTL 50, PN 25, connection 1" NPT male, approval for Ex-Zone 0, with PTB-test certificate, sensor length: 66,5 mm
26 136 Liquid level transducer FTL 320, with intrinsically safe electrical input and relay output, 1-channel, power supply 230V AC, built-in housing
14 120 Sealing in the level sensor with pressure test
26 952 Electrical control cubicle for installation inside a building or outside the hazardous area
20 716 Bypass pipe for the regulated vapour phase with ball valve, with integration behind the middle pressure regulator



Spare Parts for Dry-Type Vaporizer

- Order No. Execution
15 902 Safety relief valve, PN 63, 1/2" NPT male, setting pressure 25 bar, with TÜV-certificate, without weep hole, with type approval
20 441 Thermostat, make contact at 55°C
20 442 Thermostat, close contact at 75°C
20 443 Temperature limiter, break contact at 100°C
20 445 Solenoid Valve, PN 25, operating pressure 0,2 to 16 bar, 230 V, 50 Hz, both sides 15 mm cutting ring union

Dry-Type Vaporizer type XP, for propane / butane, indirectly electrically heated, test pressure 26 bar, explosion-proof in accordance to NFPA-Pamphlet No. 58 and 70, with test report 2.2 to EN 10 204

These compact vaporizers work fully automatic and are delivered ready for connection to plant facilities including insulation. They are equipped with a solenoid valve in the vaporizer inlet, a float switch as anti-flood protection, sensors for temperature control and a safety relief valve (without TÜV-approval) with a setting pressure of 17,2 bar, power supply is 400V / 50Hz. Other voltages on request.

Order No.	Type	Capacity kg/h	Power Supply kW	A mm	B mm	C mm	D mm	E NPT-fem	F NPT-fem	Weight kg
20 801	XP	25	3,3	572	216	286	308	3/4"	1/2"	29
20 802		50	6,5	743						36
20 803		100	13,1	743						36
20 804		160	20,0	914						52
20 805		240	30,0	1041				1"	3/4"	57
20 806		305	40,0	1219						64

